

**A New Avtaar**

## Moving Ahead with a New Look and a Grander Vision

The change of logo by Sahajanand Laser Technology Ltd is more than just a visual exercise. It is an attempt to re-brand its position in the global industry while announcing the fact that the company is fully prepared to tackle the biggest challenges that the future mode of industrialization may pose.



From L-R: Mayank Patel, Director; Dr Arvind Patel, Chairman & Managing Director; Maulik Patel, Executive Director, Sahajanand Laser Technology oriented on their re-branding strategy.

If there is anything that is an inevitable element of life, it is change. The world, for instance, has been in a constant state of evolution since time unknown, always moving towards something different, something bigger. And this is a reality that Sahajanand Laser Technology Ltd (SLTL) has always held as its core philosophy, reflected as recently as in the change of its logo, thus marking a fresh step towards re-branding of the company and its products. "This change is in line with the ambition to place SLTL in such a position that it gets established as an organization

that is incessantly marching forward via consistent innovation and progress. The intention was very clear behind this big leap: to establish a new identity that is not restricted to laser solutions only, which limits the overall image of the company," explains Maulik Patel, Executive Director, SLTL. If we compare the old logo with the new logo, we will be able to observe some similarities and will be able to find a connect. With SLTL having already proved its mettle in diverse sectors, the logo should be symbolic of its achieve-

ments so far. The new logo does just that: it depicts progress in a continuum which is the company's new brand philosophy.

### The journey so far

A pioneer in the world of lasers in India, SLTL has catered to the needs of various industries, offering total solutions with a wide range of laser systems for diversified industrial applications such as laser cutting, marking, welding, micro-machining, solar cell scribing/cutting, diamond processing, etc. In fact, SLTL is one of the few manufacturers in the world

providing customized CNC laser solutions. The history of the company dates back to 1992 with the setting up of a base factory in Gandhi Nagar when it introduced for the first time in India a laser system for the diamond industry. Now, it is one of the world's largest manufacturers of CNC laser systems for the diamond industry. The company also provides solutions to scientific and research institutes and government organizations in India and abroad. It exports its systems to the USA, Russia, Sri Lanka, Thailand, Namibia, Botswana,   
Continued on page 2.





Ball Transfer Units

**Hall 3A - Stall D110**



AMCATS PVT. LTD.

TEL: 022 - 6146 4444 / 45

APEX PRECISION MECHATRONIX PVT. LTD.

EMAIL: sales@apexprecision.co.in



Continued from page 1.

Saudi Arabia, Iran, Dubai, Switzerland, Angola, Israel, Armenia, China, Poland, South Africa, Singapore and other countries. "SLTL has been actively contributing in multiple dimensions, providing problem-solving laser technology across multiple industries like diamond, RF and microwave, solar, medical, defense and aerospace and many others. The SLTL Group would now like to showcase its contribution across all such sectors through a single identity," states Patel.

**The road ahead**

For the SLTL Group, there is an ambitious target to achieve. It envisions reaching out to 100 countries by the end of 2020. "We believe in continuous innovation and challenging our capabilities to deliver high-tech solutions valuable for all strata of industry. Our future plans vastly emphasize upon the smart manufacturing and digital technologies. It starts with automa-

tic as well as modular machines that can be upgraded with your business as it grows, and this is something we are showcasing at IMTEX 2018," he informs.

In 2017, SLTL got an opportunity to deliver five large-sized laser cutting and laser welding machines critical for rail coach manufacturing and other customized solutions for industrial manufacturing needs. This year,

along with its re-branding exercise, SLTL is putting on display its powerful 4 kW cutting machine and automatic smart sheet storage solution, Opti-Store, which assists in production, enhances productivity and safety, while saving more than 80 sq mt of floor space. "We always strive to be five times ahead of the current technology and deliver solutions with our sight focused well ahead into the future," says Patel.



**Sahajanand Laser Technology Ltd (SLTL)**  
www.sltl.com  
Hall & Stall: 2A / B-106

**Knowledge Sharing**

**CONNECT: Nurturing Talent**



Source: IMTMA

In conjunction with IMTEX FORMING 2018, IMTMA has organized 'Connect', an awareness program that aims to impart knowledge on the machine tool industry to young engineers. It's an opportunity for mechanical and electrical engineering students to gain clarity on what lies ahead of them in terms of rewards and challenges in the manufacturing industry. By interacting with industry experts, the students get to understand the role of machine tool industry in the manufacturing industry growth and also that of an engineer.

'Connect' is IMTMA's attempt at preparing the young engineers for the road ahead.

**CONNECT @ Hall 4**

27 Jan 2018		
28 Jan 2018		
29 Jan 2018		

Register at student registration counter at Entry Plaza

**FARO**

IMTEX 2018 | B102 - HALL 3A  
Bangalore International Exhibition Centre, India  
25 - 30 January 2018

**MEASURE WITH CONFIDENCE**



**Accurate & Portable Tools for Part Inspection**

- Quickly & Easily Verify Parts to CAD Model
- Simple, Intuitive Interfaces
- Contact & Non-Contact Solutions
- Portability – Measure Where You Make It

EMPOWERING QUALITY

www.faro.com/india | Hotline: 1800.102.8456



Industry-Academia Collaboration

Research Works by the Academia Garner Rave Reviews

The i2 Pavilion initiative by IMTMA at IMTEX Forming 2018 is bearing the desired fruit. The academic institutes are amassing overwhelming response from the industry players keen to exploit their research in developing new technologies that they can then use to develop new products. Here's a look at another set of innovative works from institutes across the country.

**"Finite Element Modelling of Backward Flow Forming of Ti6Al4V Alloy"** - IIT Bombay, Metallurgical Department, Mumbai.

The research reveals that flow forming is a controlled metal spinning process where a preform material is displaced axially along a rotating mandrel, while the internal diameter is kept constant.

**"Synthesis and Characterization of Shape Memory Polymers"** -- Jain University, Ramanagara District.

The project shows that shape memory polymers (SMPs) exhibit the capability of changing their shape in a predefined behavior in response to externally imposed stimuli.

**"Investigating the Effect of Tool Geometry on the Strength of Friction Stir (Resembles Hot Working Process) Welds"** -- KLS Gogte Institute of Technology, Belagavi.

In the present work, a successful attempt was made to join 3 mm thick aluminum plates on retrofitted computer numerically controlled vertical milling machine. Further, the effect of different tool geometries on weld strength was investigated. It was found that tools with specific geometrical changes resulted in superior welds as compared to others.

**"Tool Life Improvement using Cryogenic Treatment"** - Maharashtra Insti-

tute of Technology, Aurangabad.

The research presents that tool life improvement using cryogenic treatment is a heat treatment unlike other treatments wherein heat is extracted from the material being treated for a particular period at temperatures ranging from -1530C to -1960C in a specially designed furnace.

**"Investigations on 316L Stainless Steel in Machining with Biodegradable Oils as Cutting Fluid"** - Marathwada Institute of Technology, Aurangabad.

The research presents how biodegradable oils are finding their way into lubricants for industrial and transpor-

tation applications.

**"Analysis of Single Point Cutting Tool for Improving Natural Frequencies"** -- MIT ADT University, Pune.

The research presents that vibrations produced during machining process hamper the surface finish of the work piece. It is, therefore, necessary to completely avoid vibrations or at least reduce vibration amplitude. This project work is directed towards a small part of this process.

**"Retrofitting a Press Brake Machine with CNC Back Gauge"** - New Horizon College of Engineering, Bangalore.

In the current project, an electric drive system for precision control of CNC positioning system is designed, assembled and experimentally tested on hydraulic press brake machines. CNC-controlled back gauges use hard stops to position cut parts in order to place bend lines in the correct position.

To know about the various other projects by the above institutes, visit Hall 4.



Academicians at their booths at IMTEX Forming 2018, showcasing their research works to the industry fraternity.

Source: Magic Wand Media Inc

3





**Best choice.**

Bystronic Laser India Pvt Ltd | 7-C Tadiwala Road, Pune 411001 | 91 20 67294800 | www.bystronic.com | Hall 4 Stall No. B106

Xact Smart 160



Visitors' Views

A comprehensive exhibition



“ It is a wonderful experience to have all the machine tools manufacturers under one roof. IMTEX FORMING 2018 has displayed several innovative ways of manufacturing. It has covered everything from material handling to robotics.”

**SN Dileep**  
Unit Head  
Apollo Tyres Ltd

IMTEX 2018 showcases current trends



“ I am from R&D space with my basic area being fine-blanking tool design. Since I basically design components, it's important that I stay updated with regard to new technologies in the forming area. The event does justice to people coming in search of information that's relevant to their area of expertise. As of me, I have amassed enough knowledge to sustain me until the next time.”

**Rohit Patil**  
Assistant Manager  
Tube Investments of India Ltd

The event is different from others



“ IMTEX FORMING 2018 is highly informative and at the same time, is different from other industrial trade events. It lives up to its reputation of showcasing the latest in trends. The technologies that are being displayed are path-breaking and innovative. Advances in laser cutting are a sheer delight to witness at the event.”

**Ankit Kothari**  
Proprietor  
Kandla Metals & Polymers

The seminar touched upon latest topics



“ I attended the seminar which covered a lot of issues. It was quite a comprehensive event and the issues were addressed in great detail. I did get informed on many topics. The discussion on the hydroforming process was particularly interesting. The discussion on the hydroforming process was particularly interesting.”

**Jothivarman Ramamoorthy**  
Manager – Marketing  
Danieli India Ltd

Industry Delegates

IMTEX, a good source of information



"Coming to IMTEX is a routine exercise for us but this is our first time to IMTEX FORMING expo. We are on an expansion drive and need to install some additional sheet metal machines such as bending machines, plasma cutting machines etc. Our purpose here is to find prospective suppliers or manufacturers of those machines and also to check their prices. IMTEX FORMING, therefore, is quite crucial for us at this stage".

**B Saravana Sridhar**  
General Manager – Operations  
Sieger Spintech Equipments Pvt Ltd

The event is a great initiative by IMTMA

"IMTEX FORMING 2018 is an admirable effort by IMTMA. The association's efforts to make the Indian Machine Tools Industry achieve global standards are commendable. The event is serving several purposes. It just does not expose the Indian machine tools users to the latest market trends and technologies, but also has an educative value to it. The engineering and technology students who come to visit get to witness ultra-modern machinery and gain knowledge about it, something that does not happen in their college laboratories. Immense thanks to the organizer and all their associates".

**RK Jaiswal**  
Development Officer  
Department of Heavy Industry  
Ministry of Heavy Industries & Public Enterprises  
Government of India



Buyer-Seller Meet

Networking Platform

IMTEX FORMING 2018 offers a golden opportunity at the show for buyers and sellers from several countries to interact and strike deals.

Concurrently with IMTEX FORMING 2018, Indian Machine Tools Manufacturers' Association (IMTMA) has organized a Buyer-Seller Meet 2018 by inviting potential buyers of metal forming machine tools and allied equipment from target overseas markets to explore mutual business opportunities.

Yesterday, besides Indians, delegates from Sri Lanka, Japan and China were present in the international lounge for discussing their needs and taking counts of the latest offerings. IMTMA

also organized a guided tour for the international delegates.

Here is what the participants had to say about their experience:

"Indian market is expanding very fast. We have special interest in displaying our sheet metal technology here, which

I believe, can increase the productivity of the Indian manufacturers. Our machines are high-tech products that can increase

the quality of outputs from the Indian manufacturers".

**Tetsuo Oohori**  
Secretary General  
Japan Forming Machinery Association (JFMA)

"I am a regular participant at IMTEX FORMING exhibitions. We are in the



steel fabrication business, thus, we always look for the latest forming and tooling machines. We sourced some machines

for our company from the last tools' exhibition. Although, we have been using some Indian machines in our workshops, we still have not sourced any machines from Indian manufacturers for bending and punching. We are using machines from Japan and Germany. IMTEX showcases various technologies under one roof, thus making it easier for us to update our knowledge".

**TAS Premlal**  
Chairman & Managing Director  
Pubudu Engineering Pvt Ltd, Sri Lanka  
"Indian market is quite big compared



to other markets like Israel, Russia and many other countries. Our intention behind coming to India is to explore new business

opportunities and try to make as many clients as possible. Machine component manufacturers are whom we reach out to. We rarely source machine tools from India; we are mainly interested in exporting our complete machine tools to India".

**Alex Mey**  
Guangzhou Baisheng Electron Technology Co Ltd



From compact to complex:  
**The scalable  
Beckhoff CNC.**



Industrial PC



I/O system



Servo drives



[www.beckhoff.co.in/cnc](http://www.beckhoff.co.in/cnc)

PC-based controllers from Beckhoff cover the whole range of high-precision CNC applications, from compact to complex.

- Highly scalable: the TwinCAT software platform for engineering and runtime
- Highly scalable: the Industrial PC range with processors from Intel® Atom™ to many-core
- Highly scalable: the I/O system for all signals and fieldbus systems
- Highly scalable: the highly dynamic servo technology for all performance classes
- Highly scalable: the safety solution, from system-integrated I/Os to drives



**POWERING YEAR 10**

Beckhoff Automation Pvt. Ltd.  
Pune – 411 006, India  
Phone: +91 20 40 00 48 00  
info@beckhoff.co.in

New Automation Technology

**BECKHOFF**

Research and Development

# Paving the way for better tomorrow!

**AS Kiran Kumar, Vikram Sarabhai Distinguished Professor & Former ISRO Chairman feels resources allocated to innovation can yield competitive advantages to the nation's industry.**

Of the myriad applications for metal forming, none is perhaps as challenging and fascinating as space research. AS Kiran Kumar should know. A Vikram Sarabhai Distinguished Professor with a four-decade career at ISRO behind him, Kumar has pioneered many an innovation in the Indian Space Research Organisation (ISRO), including instruments aboard the prestigious Chandrayaan-I and Mangalyaan space crafts. "We today stand in the place where the Indian industries can take a portion of the global market of the space industry," he remarks, "Space, as you are aware, is now going to be one of the frontiers, whether it is space travel, space exploration, or space exploitation."

**From contributors to creators**

"While we have missed earlier industrial revolutions, now is our time to lead, particularly when the Indian intellectual capability forms the key ingredient in all the value chains globally," says Kumar, "but the infrastructure is actually somebody else's. As a result of that, the real benefits of such developments go to somebody else." To change the paradigm, he suggests creating new infrastructure with architecture from Indian entrepreneurs. Presenting glimpses of exciting new technologies, he adds, "Artificial intelligence or neural network learning are fast becoming part

of new manufacturing and metal forming processes. With the help of nano technology and other capabilities, we are able to combine different materials within the same object, instead of joining separately formed parts."

**Call for innovation**

Reiterating his faith in India's intellectual resources, Kumar suggests that industries should step up their R&D investments if we are to become world leaders in production. He cites technology developed in ISRO during his tenure, "ISRO is today making use of indigenously developed batteries for launch vehicles as well as for the satellites. Very soon the same basic technology will be available for the automotive industry."

For meaningful development, he stresses on the role of government as well as business. "Government's role will always be enabling, as it has to provide the basic infrastructure and ecosystem," he says, acknowledging the risk behind investing in new avenues. Highlighting the potential for industries to contribute towards development, he says, "As metal forming and

tool technology keeps improving, it is for industry captains to make sure that they spend some more money in the R&D and really go ahead of the global market. Otherwise we will continue to be followers instead of leaders."

As we strive to catch up with deve-

loped nations, home-grown and proprietary, technology can make the difference between a nation that leads and one that follows. There are no shortcuts on this path, however, because big ambitions demand big risks and only big risks can yield big rewards.

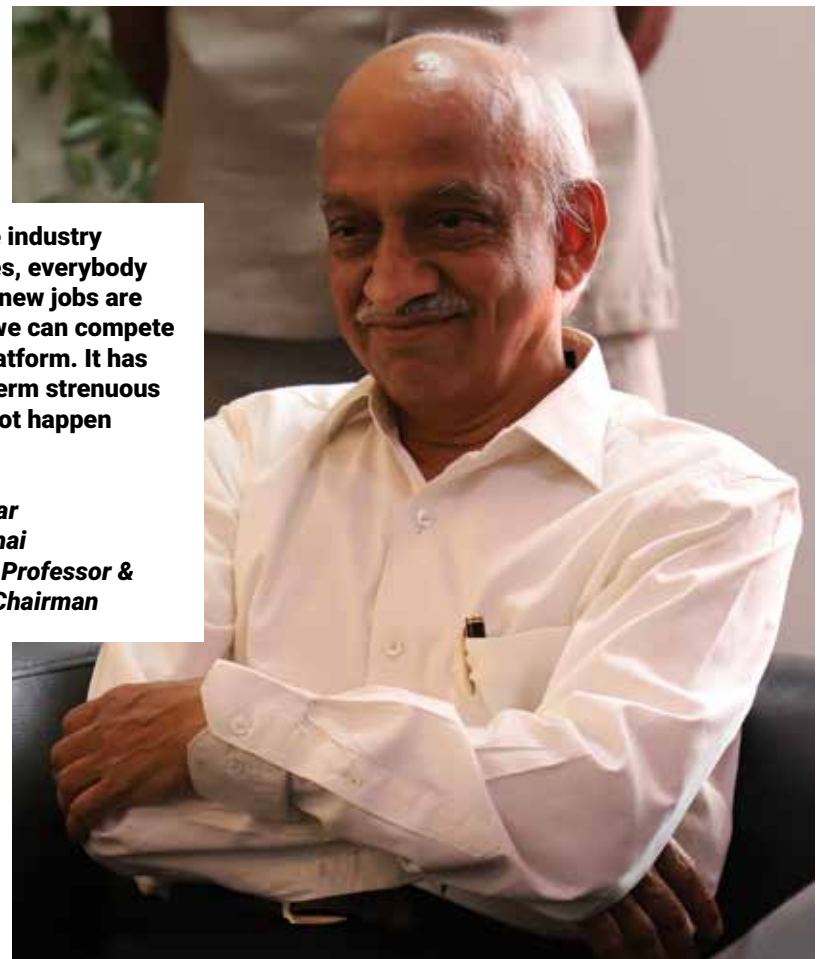

**“Once the industry flourishes, everybody is benefitted, new jobs are created, and we can compete on a global platform. It has to be a long-term strenuous effort. It cannot happen overnight.”**

**AS Kiran Kumar  
Vikram Sarabhai  
Distinguished Professor &  
Former ISRO Chairman**

**Kjellberg**  
CUTTING AND WELDING INDIA

**Silence is Golden  
Silent Cut**

Precise and fast of plasma cutting do not have to be loud: Go into the future with us and our new cutting technology - live at Imtex 2018, hall 4, stand B113.

up to -15db  
plasma 4.0  
next generation

**KEEP CALM AND CUT SILENTLY**



More Information

Phone: +91 20 26741042 | Fax: +91 20 26741001  
vertrieb@kjellberg.de | www.kjellberg.de



www.kjellberg.de



Amada India

# Fiber Laser line-up



AMADA  
Fiber Laser Lineup

Amada developed its own fiber laser oscillator as the laser machine manufacturer for the first time

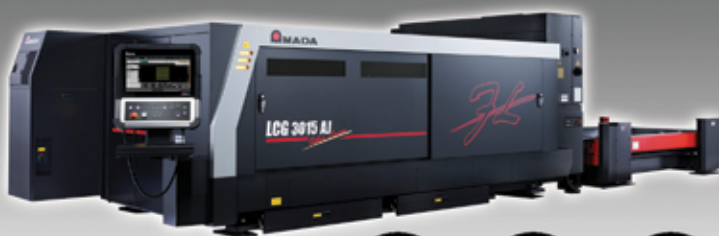

3kW

6kW

9kW

AMNC 3

Global standard  
fiber laser cutting machine

**LCG-3015AJ**

\*Also available as LCG-4020AJ



3kW

AMNC 3

Energy saving, v-lot production,  
wide range fiber laser machine

**ENSIS-3015AJ**

\*Also available as ENSIS-4020AJ



Hall No. 4  
B108



**Amada (India) Pvt. Ltd.**  
**Technical and Vocational Center**  
No.60, KIADB Bengaluru Aerospace Park,  
Singhalli Village, Budigere Post, Bangalore,  
North Taluk - 562 129, India.  
Ph: 080 - 71100200





The German Connection

# "Business with India is holding up well"

IMTEX FORMING is a premier event for German manufacturers of sheet metal forming machinery to showcase their performance capabilities in the Indian market, points out Dr Wilfried Schäfer, Executive Director, VDW (German Machine Tool Builders' Association).

**Expectations from IMTEX**

"India is a significant market for the German machine tool industry, offering massive potential. This means that IMTEX Forming enjoys a high level of perceived importance as well. It is a premier event for German manufacturers of sheet metal

forming machinery to showcase their performance capabilities in the Indian market. The VDW has for many years been supporting the German companies participating in this event and for this year's edition there are at least 30 German firms that have come on board.

**Business with India**

Fundamentally, business with India is holding up well, even though the growth motor is currently faltering a bit. Germany is the third most important supplier of machine tools, with a share of 12%. In the first three quarters of 2017, machines worth around Euro 155 million were delivered, 38% more than in the equivalent period of 2016. India thus ranks 14th among our most important markets. The country's industrial sector requires the entire spectrum of modern-day metalworking technologies. The principal categories involved last year were machining centres, grinding machines, parts and accessories, gear-cutting machines and lathes.



India thus ranks 14th among our most important markets. The country's industrial sector requires the entire spectrum of modern-day metalworking technologies."

**Dr Wilfried Schäfer, Executive Director of VDW (German Machine Tool Builders' Association)**

Orders from India, by contrast, are somewhat sluggish at present. The first nine months of 2017 saw a fall of 18%. However, we are confident that the disruptions caused by President Narendra Modi's ambitious reform programme will be temporary. It is in order to boost their business once again that so many German firms have signed up for this show.

Even lighter and stronger than aluminium are carbon fiber-reinforced plastics (CFRPs). CFRP forming has been in use for a long time already, but due to its high price is still confined to specific applications, like the electric car from BMW, which is manufactured primarily from CFRPs and aluminium. Also, an entirely new and very efficient production technology that may in future gain in importance is sheet bulk metal forming. It combines the advantages and design options provided by sheet metal and solid material forming. For all these variants, German machine tool manufacturers offer attractive solutions for Indian customers. Our collaboration with the automotive industry is one example."

**VDW (German Machine Tool Builders' Association)**  
www.vdw.de  
Hall & Stall: 3A / Q-105

**German Machine Tool Imports from India - Overview\***

	2013	2014	2015	2016	1-3Q 2017
EUR millions	11,3	14,0	19,2	17,7	13,9
%-Change to previous year	-2	+23	+38	-8	-6
%-Share in total imports	0,4	0,4	0,6	0,5	0,6
Import rank	27.	23.	21.	21.	20.

Mill. EUR

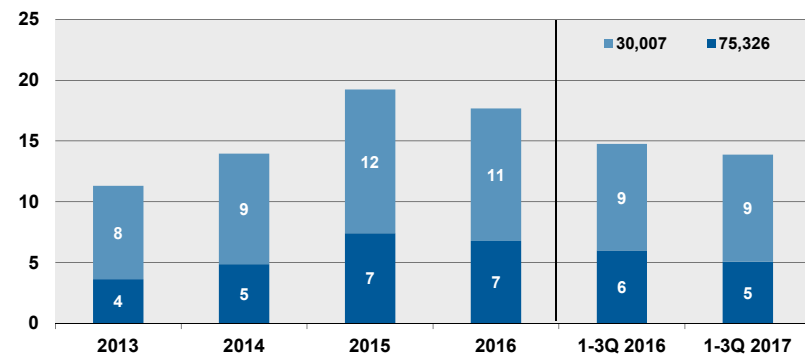

**Most important machine type 1-3Q 2017 (Mill. EUR)**

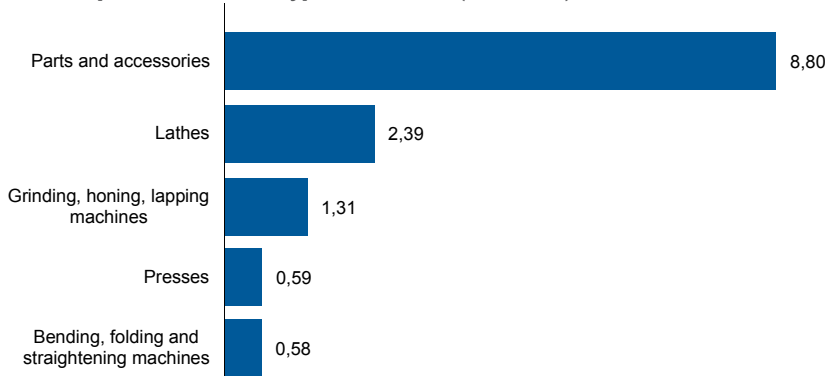

Machine tools including parts/accessories:  
HS-Harmonized System Codes 8456-8463, 84663 93/94, 8479 40  
Sources: Official trade statistics Germany, VDW  
VDW, German Machine Tool Builders' Association, 19.01.2018

**New Metal Forming Technologies**

One definite trend is hot-forming of steel sheets, which guarantees enhanced flexibility in forming operations while at the same time providing higher material hardness. And it enables different levels of hardness to be produced significantly more simply in a single work piece. One entirely new and very exciting topic is hot-forming of aluminium. Thanks to its high mechanical strength, this lightweight material is gaining steadily in perceived importance throughout the automotive industry.

**Press Brakes**

## An ultra-high precision, compact bending solution from Amada

Amada introduces a new generation press brake, HG1303 with sheet follower for bending heavy and long jobs. The ultra-high precision, high-speed compact bending solution features an advanced Dual Servo Power drive system that provides the ultimate in bending control and accuracy. HG series press brakes have high rigidity frame for long lasting performance. Patented hybrid crowning system automatically provides

consistent angular accuracy. Larger open height allows deep box bending. 8-axis backgauge speeds set-up and BI-S sensor adjust the bend angle "on line". It results in a reduced manpower consumption due to easy handling of heavy and long parts using sheet follower. Human error and operator safety is taken care by Laser safe. It also features a new AMNC 3i controller with a multi-touch display.



Source: Amada India Pvt Ltd

**Amada India Pvt Ltd**  
www.amadaindia.co.in  
Hall & Stall: 4 / B-108

Amada's HG1303 Press Brake with sheet follower.



Laser Cutting

# Innovation is the Only Way to Succeed

One of the leading manufacturers of advanced machining solutions in India, Yamazaki Mazak India, is back at IMTEX Forming 2018 with its wide array of innovations and a commitment to fortify productivity and efficiency of its users.

Yamazaki Mazak India Pvt Ltd, a leader in the manufacture of advanced technology solutions including multi-tasking, 5-axis, milling, turning, CNC controls and automation, has always been a believer in the power of innovation. A regular at IMTEX exhibitions, the Pune-based company, is here yet again with the latest in its offerings from the company's R&D facility at the headquarter in Japan: the OPTIPLEX DDL series.

"The new Mazak Direct Diode Laser (DDL) technology is an exclusive breakthrough laser platform that delivers higher performance and reliability than traditional fiber or other solid-state

laser generation systems," explains Pramod Kore, General Manager, Service & Tech Support, Yamazaki Mazak India Pvt Ltd.

According to Kore, the new offering is poised to be a gamechanger with cutting speeds that are faster than fiber generators of the same power in its power range. The Optiplex DDL boasts of wall-plug efficiencies of 45 percent as compared to 35 percent for fiber, along with a new PreviewG control and a drive package.

### Capitalizing on IMTEX

Speaking on the company's regular participation at the event, Kore

explains, "IMTEX is a grand platform to showcase our innovations, new products, services and communicate the key message to the market. It is a medium which we use for face-to-face interaction and to encourage consumer engagement. It helps us to strengthen our brand value, take our public relations to the next level, attract new customers and strengthen the loyalty of the existing customers."

### Prompt makes perfect

An integral part of the company's presence in India is its accessibility and availability for its customers here.

"A network of more than 40 factory-trained Mazak service representatives visit our customers' location within 24 hours under most circumstances," he shares.

Along with offering a prompt service to its customers, the company is equally strong in its range of products. Its part center has more than 5000 different stock parts. "No matter what the age of your Mazak machine, you can be rest assured that replacement parts will be available at world-wide part centers. We understand the high cost of downtime. That's why our parts department operates Monday through Saturday, with the option for same-day shipment," he adds.



**“IMTEX is a grand platform that helps us to strengthen our brand value, take our public relations to the next level, attract new customers and strengthen the loyalty of our existing customers.”**

**Pramod Kore  
General Manager  
Service & Tech Support  
Yamazaki Mazak India Pvt Ltd**

**Yamazaki Mazak India Pvt Ltd**  
www.mazakindia.in  
Hall & Stall: 4 / B-102

Source: Magic Wand Media Inc

# AFDEX

Adviser for metal Forming process Design EXpert

Altair | Partner Alliance  
One Platform. One License. One Source. All Access.

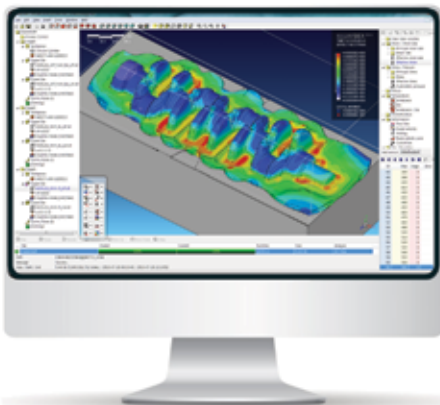

Visit us at **Hall 4 L104** to know more about  
**state-of-the-art metal forming  
simulation technology**

Just run it to forge the future



Leveling Machines

# Meeting the Demands of Tomorrow

With its decades of expertise in making levelers, ARKU Maschinenbau GmbH is now keen on tapping the India market.



Source: ARKU Maschinenbau GmbH

Over the last 50 years, ARKU Maschinenbau GmbH has grown to become a market and innovation leader for levelers. The company offers machines and services with high value retention. In doing so, it ensures process reliability and efficiency for customers all over the world. As Andreas Hellriegel, VP (Business Development), ARKU Maschinenbau GmbH, puts it, "To successfully handle tomorrow's challenges, we are positioned to meet the demands of the future. Yet we also remain true to our origins: precision is our promise."



ARKU's deburring machine - the EdgeBreaker

can help them to solve their challenges and develop their business," he says. At the show, the company is introducing all its machine types: precision levelers, deburring and edge-rounding machines, diverse coil lines as cut-to-length and slitting lines, press feeding units and press feeding lines, and coil preparation lines for roll formers.

**Leveraging IMTEX to create awareness**

Targeting decision-makers and technocrats from various manufacturing industries such as automotive, railroad equipment, shipbuilding, construction and furniture, and laser job shops, the company sees the event as an opportunity to take the next step forward by promoting its expertise of leveling and deburring metal parts and coils in the Indian market. "We want to create awareness among potential Indian customers that we provide

engineering expertise to many manufacturing industries. It's essential for us to inform the visitors how our machines can enhance their productivity and how we can help to increase the quality of their parts and/or coils so that they can achieve and exceed their expectations," adds Hellriegel.



**The face-to-face meetings with our potential Indian customers at IMTEX FORMING 2018 will enable us to better understand local requirements and create awareness that we provide engineering expertise to many manufacturing industries."**

**Andreas Hellriegel  
Vice-President (Business Development)  
ARKU Maschinenbau GmbH**

**ARKU Maschinenbau GmbH**  
www.arku.com  
Hall & Stall: 4 / A-133

**Reaching out to local customers**

Hellriegel believes that a show like IMTEX Forming enables the company to better understand local challenges and to work on solutions for its local customers while meeting them personally at the their booth. "These face-to-face meetings will enable us to better understand local requirements. Of course, it is the best occasion for us to inform the visitors at our booth about our latest developments and how we

**Fiber Laser Cutting**

## On the Cutting Edge

Laser cutting is a thermal cutting process for processing sheet metal. The laser beam is created by the laser source (resonator), conducted by a transport fiber or mirrors in the machine cutting head where a lens focuses it at very high power on a very small diameter. This focused laser beam meets the sheet metal and melts it. Bystronic uses two types of laser sources: Fiber Laser and CO<sub>2</sub> Laser.

Laser cutting is extremely versatile. In addition to flat materials, tubes and profiles can also be processed by laser cutting systems. Primarily steel, stainless steel and aluminium are cut. The thickness of the processed sheet metal ranges from 0.8 to 30 mm.

**Fiber laser**

Fiber lasers are the newest development in laser cutting. The laser beam is created by an active fiber and transmitted over a transport fiber to the machine cutting

head. Fiber lasers are significantly smaller than CO<sub>2</sub> lasers and generate twice as much power from the same amount of current. A fiber cutting system is primarily suited for processing thin to medium thick sheet metal. It also cuts non-ferrous metals (copper and brass).

**ByStar Fiber**

Highest parts output and premium cutting quality for the high range of sheet thicknesses can be achieved through

Source: Bystronic Laser India Pvt Ltd



ByStar Fiber

	ByStar Fiber 3015	ByStar Fiber 4020
<b>Nominal sheet size</b>	3000 mm x 1500 mm	4000 mm x 2000 mm
<b>Maximum simultaneous positioning speed</b>	169 m/min	169 m/min
<b>ByVision Cutting operation and manual control unit</b>	*	*
<b>Circumscribed circle diameter of the rotary axis</b>	30-315 mm	30-315 mm

ByStar Fiber.

Thanks to the intuitive ByVision Cutting user interface, a maximum degree of operating convenience and transparent process control can be obtained; It offers unrestricted access to the cutting area from the machine's long side.

**Bystronic Laser India Pvt Ltd**  
www.bystronic.com  
Hall & Stall: 4 / B-106

**Clamping System**

## Hydraulic Quick-Action Die Clamps from Guthle

Hydraulic clamps can be used to reduce downtime when setting up wherever dies need to be changed frequently. With a defined clamping pressure, die clamping is extremely precise as all clamping elements are effective simultaneously. Integral features of such a die clamping system include complete die protection in conjunction with effortless operation. The minimum handling requirements save considerable time.

**Product range**

The Rollbloc product range includes five different hydraulic clamping systems for the purpose of clamping dies (press table and ram): Rollbloc Hollow piston clamp, Sliding clamp, Ledge clamp, Wedge clamp, and Block clamp.

A die change can be carried out particularly fast when die base plates of the same size are used for quick die change. Special sets of hydraulic valves are used for controlling the Rollbloc hydraulic clamps.

The Rollbloc hydraulic unit produces the necessary clamping pressure in an independent operating system. Hydraulic components, valve kits, hydraulic distributor plates and hose connections are used as supplementary components.

Advantages of Rollbloc Hydraulic Quick-Action Die Clamps:

Extremely precise and effective die clamping pressure.

Complete die protection with effortless operation.

Minimum handling that saves considerable setup times.

Rollbloc hydraulic quick-action die clamps.



Source: Guthle Pressenspannen GmbH

**Guthle Pressenspannen GmbH**  
www.guthle.com  
Hall & Stall: 3A / J-104



Knowledge Sharing

# Hot Forming: A New Solution

A presentation by ISGEC-AP&T at the International Seminar on Hot Forming Technology, the demand for which is expected to grow exponentially...

Traditionally, complex sheet metal components fabrication involves an intricate combination of cutting, grinding, stretching and matching rough-shaped component elements with final assembly often requiring welding, riveting, and various other fastening methods. Today, a much more affordable alternate manufacturing solution is to use processes such as hot forming. Because of the growing global requirements for improved passenger protection and the need to reduce CO<sub>2</sub> emissions, demand for hot formed stamped parts is expected to grow exponentially in the coming years.



ISGEC and AP&T have entered into cooperation agreement for advance hot forming solutions for the Indian market.

Source: ISGEC Heavy Engineering Ltd

of the press slide makes it possible to switch between the main cylinders running the slide. By disconnecting one or more of the main cylinders of the slide, the speed during the press operation will increase and the cycle time will be shorter, which is an advantage if maximum force is not necessary. During the working stroke,

### Collaborating for advanced solutions

ISGEC Heavy Engineering Ltd is a leading manufacturer and supplier of mechanical and hydraulic presses ranging up to 12,500 T. AP&T is a world leader in production solutions for forming lightweight materials such as press hardening of vehicle parts in high-tensile steel and has been delivering production lines to metal forming companies since the 1980s. To supplement the expertise of each other, ISGEC-AP&T have entered into cooperation agreement for advance hot forming solutions for the Indian market. Hot forming solutions by ISGEC-AP&T allow the near-net forming of complex parts from metals and alloys that do not exhibit super plastic characteristics and are typically used for

shaping complex parts with simple bends or gentle contours for the automotive and aerospace industry. The finished parts are produced from a single sheet or piece of material and are effectively stress-relieved during the process, thus eliminating post-formed spring-back. ISGEC-AP&T hot forming solution consists of an ergonomic, comfortable, safe and easily operated hydraulic press, especially suited for press hardening operations. The hydraulic press operates at high temperatures, with its platens containing heaters. The parts must be pressed in stages, and should be controlled forming.

### Salient features

The press has the following

special features:

The frame sections are bolted together with four vertical tie-rods, pre-stressed to a factor of 1.5 times maximum press force. This results in a rigid frame with a minimum of deflection, guaranteeing a long service life for dies and guides. The frame parts are optimized by using advanced computer stress calculations (FEA) for critical load bearing sections of press.

The slide is controlled by double acting main cylinders. Fast closing aided by gravity leads to high speed and low energy consumption. Linear digital encoders, connected to the control system measure the slide position.

The high-speed multi-cylinder function

force and speed are fully programmable. The function is programmed and stored in the operator terminal.

The press is provided with piping for feeding cooling water to the lower and upper part of the die. The piping system consists of four circuits at the slide for the upper part of the die and four circuits at the press frame for the lower part of the die. Each circuit consists of two connections, one for incoming water and one for outgoing. All piping is connected to a central incoming connection point on the press frame.

**ISGEC Heavy Engineering Ltd**  
www.isgec.com  
Hall & Stall: 2A / B-102



**VISIT GRAVOTECH @ HALL NO. 2A / STALL NO. E102**

## NEW LASER RANGE

KEY FEATURES:



FIBER SERIES

HYBRID SERIES

GREEN SERIES

CO2 SERIES



**3D MODULE**

Highest amplitude in the world



**AUTOFOCUS**

Perfect marking in all conditions



**VISION MANAGER**

Real time marking verification

Automation

# EtherCAT P combines ultra-fast communication

With the One Cable Automation philosophy, Beckhoff enables entirely new concepts in machine and systems engineering.



The concept is based on the ability to connect automation components, decentralized terminal boxes and even entire machine modules with a single EtherCAT P cable, which carries the EtherCAT communication as well as the power supply for the system and peripherals. One Cable Automation not only reduces material costs, the time and effort spent on system installation and the risk of errors, it also enables a much more flexible design, including the possibility of a machine without control cabinets.

EtherCAT P is a technological milestone that integrates EtherCAT and power supply in a standard 4-wire Ethernet cable. Beckhoff has developed a special M8 connector for EtherCAT P with a mechanical coding that prevents mis-mating with connectors for standard EtherCAT slaves. The 24 V DC supply of the EtherCAT P slaves and connected sensors and actuators is integrated into the cable. US (system and sensor supply) and UP (peripherals voltage for actuators) are galvanically isolated, each supplying up to 3 A of current. All the benefits of EtherCAT can be retained, such as the free choice of topologies through cascability, high speed communication, optimized bandwidth utilization, continuous message processing, highly accurate synchronization, and extensive diagnostic capabilities, among others. With EtherCAT P, the US and UP currents are injected directly into the wires of the 100 Mbit/s cable for a highly cost-effective and compact connection.

even individual machine modules and robots receive power supply and control signals over a single branched cable. As a result, large control cabinets frequently used in large installations are no longer needed. Modular machine and system concepts can now be implemented with lower assembly and startup costs, reduced footprints and maximized flexibility.

Eliminating separate power lines reduces the cost of materials and assembly, as well as the occurrence of installation errors while minimizing the space requirements in drag chains, control cabinets and the machine itself. Other benefits include smaller and more clearly arranged cable runs, as well as smaller sensors and actuators. All of these features deliver a new degree of flexibility in machine design.

To simplify machine design even more, a special TwinCAT utility program is available for specifying individual power users and cable lengths, as well as deploying the most efficient EtherCAT P network. Since the system knows every user's specifications, it can also take into account the individual devices' power consumption over time. For example, if two actuators never switch at the same time, they will never require full power input at the same time. This produces additional savings potential with regard to power supplies and power supply units.

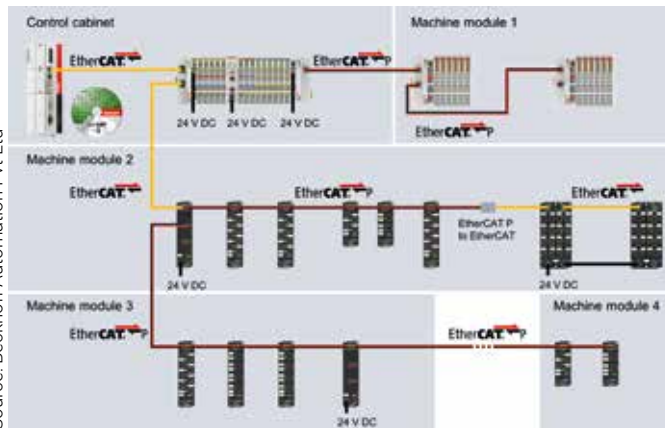

EtherCAT P One Cable Automation Master Plan.

### Plug-and-play automation possible

In the future, plug-and-play automation will deliver maximum efficiency. As EtherCAT P connectors for various power requirements become established as a standard, the idea of industrial connector strips – for 24 V and for higher power classes – is not far-fetched.

Machine designers could distribute such 'connector strips' with great flexibility and at low cost in the machine or installation, according to the individual application requirements. Such a plug-and-work design, which requires only the insertion of a matching EtherCAT P cable, would make it easy to connect the necessary sensors and actuators as well as the distribution boxes and standalone machine modules.

### EtherCAT P: From 24 V sensor to 600 V drive

EtherCAT P delivers benefits for connecting small distributed I/O stations in terminal boxes as well as for local I/O components within the process. In order to connect components with higher voltage and/or current requirements, a complete EtherCAT P connector family has been developed that covers all applications up to drives with power ratings of up to 400 V AC or 600 V DC and currents up to 64 A.

### Innovation driver in machine design

With its simpler and more flexible system cabling, OCA considerably reduces the complexity of machine design and with it, development and production costs. This is because automation components, distributed terminal boxes and

**Beckhoff Automation Pvt Ltd**  
www.beckhoff.co.in  
Hall & Stall: 3A / C-104

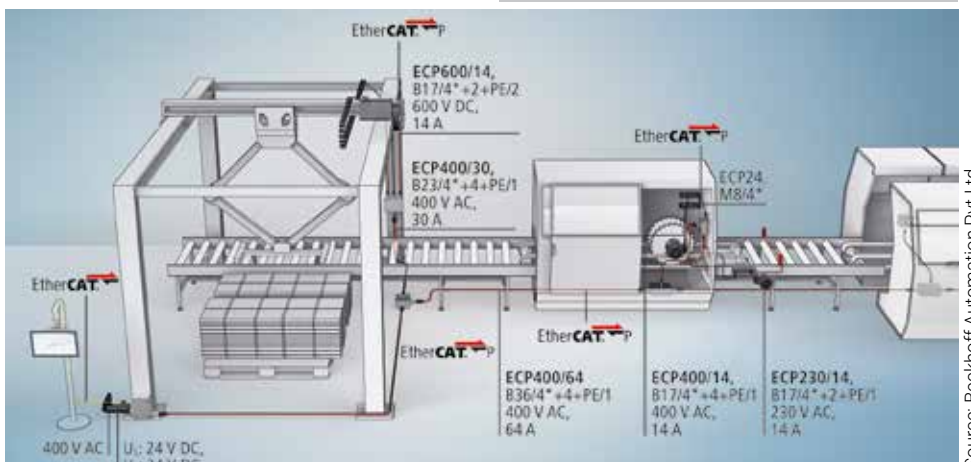

## Foundation Course in Sheet Metal Manufacturing

26 February 2018 to 12 March 2018  
IMTMA Technology Centre, Chinchwad, Pune

Overview of Sheet forming Processes

Basics of Cutting, Bending and Forming Operations

Presses and Press Lines

Type of Dies

Manufacturing process for Dies

Tryout of Dies

Assembly Techniques and Fixtures

For Registration contact :  
Abhishek Kumar Verma ; Executive Officer, IMTMA  
Tel : 020-64100182 / 64100183 ; Mobile : +91 8237960076  
Email : abhishekverma@imtma.in

www.imtmatraining.in



## Metrology

## Measuring it up Right

An account of how FARO's portable coordinate measuring machine (CMM), FaroArm met the KUKA India's needs for component alignment and parts calibration, and facilitated the robot installation process.

Behind the production of nifty robotic devices is a commitment to quality management, which involves strict adherence to several sets of guidelines throughout a manufacturer's supply chain. One such company that places great emphasis on quality is KUKA Systems India Pvt Ltd (KUKA India). Based in Pune, India, KUKA India supplies automation solutions to manufacturers, with a specialization in welding lines, press automation, and final assembly lines for the automobile industry. The fully-owned subsidiary is part of the KUKA Robot Group - one of the world's top suppliers to the robotic industry.

## The problem

As KUKA India endeavours to provide its customers with total reliability in its automation solutions, the company must ensure that stringent quality checks are imposed on its output before the final products leave the production line.

For that reason, the quality and certification team at KUKA India embarked on a search for a suitable measurement solution. "When we first set up the plant, we knew we needed a flexible tool that



The FARO Laser Tracker Vantage is the ideal laser tracking solution for large volume measurement.

can handle both small and large parts because our work involved jigs and fixtures of varied sizes," shared Pravin Kulkarni, Senior Engineer, KUKA India. "It was imperative that we invested in a high precision device that provides accurate data and reduces human error. In addition, because we design and customize solutions for our customers, we also had to satisfy the need for part calibration."

"Our European counterparts suggested FARO solutions as they enjoyed great results with FARO's portable coordinate measuring machines (CMMs) in their Helzberg plant," revealed Kulkarni.

FARO is the world's trusted source for 3D

measurement, imaging and realization technology. The company develops and markets computer-aided measurement and imaging devices and software.

## Solution, the FARO experience

After a thorough evaluation, the FARO team recommended its bestselling portable CMM solution – the FaroArm – to KUKA India. "Based on our measurement needs and concerns, FARO team found that the 12-ft FaroArm would serve us the best," said Kulkarni.

With the FaroArm, KUKA India was able to measure small jigs and fixture components with high levels of accuracy and repeatability. Apart from the

“Not only did the FaroArm help us to achieve high accuracy standards in the assembly line, it also came in handy during the calibration and installation process, allowing us to verify the alignment of various robotic parts.”

**Pravin Kulkarni**  
Senior Engineer  
KUKA India

dimensional analysis, the FaroArm met the company's needs for component alignment, parts calibration, and also facilitated the robot installation process. "The FaroArm was an excellent purchase as it helped us greatly in our production process," Kulkarni added. "Not only did the FaroArm help us to achieve high accuracy standards in the assembly line, it also came in handy during the calibration and installation process, allowing us to verify the alignment of various robotic parts."

**FARO Business Technologies**  
www.faro.com/india  
Hall & Stall: 3A / B-102

13

**FRESHERS**  
Train yourself to be  
Industry Ready Engineer



**DESIGN INSTITUTE**  
Machine Tool Design Powered by Technovation

**INDUSTRY**  
Train Freshers / Hire  
Industry Ready Engineer



HANDS-ON TRAINING PROGRAMME ON

## ELECTRICAL & ELECTRONICS FOR MACHINERIES

Schedule : 2 Feb 2018 to 10 March 2018

Venue : IMTMA Design Institute,  
BIEC, Tumkur Road, Bangalore

Timing : 0900 - 1730hrs  
Monday to Saturday

### COURSE OUTLINE

- ⇒ Fundamentals of electrical design
- ⇒ Introduction to Mechatronics
- ⇒ Basics of PLC Programming
- ⇒ CAD Training
- ⇒ Electrical Design for CNC machine
- ⇒ Electrical Design for Industrial machine

### STATE-OF-ART FACILITIES

- Advanced CAD lab and A/V class rooms
- CAD tools : ePLAN & AUTOCAD
- Experienced Industry professionals as faculty
- Live projects, PLC Programming and Industry visits
- SIEMENS, FANUC & MITSUBISHI Program simulation kits
- Facilitate placement at core industry

For registration contact : Rathan ; cell : 9743180085; email : rathan@imtma.in

Metal Marking

# Gravotech Ushers in a Revolution in Dot-Peen Technology

Source: Gravotech Engineering



The stylus follows the shape of the part.



It reaches hard-to-reach places.



Marking on inclined plane, distorted surface, uneven flatness

**G**ravotech has unveiled its latest innovation in the mechanical marking brand line Technifor: a very high amplitude 3D stylus capable of following the relief of every part to be marked. Delivering significantly reduced integration costs, versatility and superior marking results, the ability of the Technifor 3D stylus will soon win over all sectors of industry by eliminating many of their mechanical and software-related constraints:

**Perform a succession of markings**

**regardless of the shape of each work-piece:** sloping planes, out-of-flat surfaces, deformed surfaces, the stylus tip extends and retracts automatically as it follows the relief with the utmost precision.

**Cover differences in height:** With an amplitude of 18 mm, the Technifor 3D stylus makes it possible to perform 'stepped' markings, on different levels of the same work-piece - and in a single cycle no less. With no need for an actuator and without moving the marking head, it enables engraving in recesses, hollows and difficult-to-reach places.

**Mark cylindrical workpieces:** Marking multiple lines following the curve of the workpiece, it is now possible to eliminate the additional cost of installing a part rotation system.

**Offering a new dimension**  
Compatible with the entire Technifor line of pneumatic machines, this 3D stylus offers a new dimension to integrators and end-users:

**Automated lines handling a succession of parts of varying heights:** no need for complex programming or a costly Z axis on the marking head. The machine absorbs height differences instantly.

**For manual or semi-automatic production operations, the adjustment is simplified:** a single marking file for a multitude of parts.

**Superior marking results:** the quality of a DataMatrix code is very close to the results obtained with electromagnetic technology, with a homogeneity and perfect alignment of points which simplifies code reading enormously. Expanding the access to automatic marking, this innovation is a cutting-edge tool that is an effective response to the ever-increasing demands of traceability.

**Gravotech Engineering Pvt Ltd**  
www.gravotech.com  
Hall & Stall: 2A / E-102



**Would you like to be crowned a Champion of PRODUCTIVITY | TECHNOLOGY | INNOVATION....**

**Share your success stories !**

Win Cash Awards upto

**₹ 10,00,000**

No Entry Fee | Multiple Entries Welcome !

**Productivity Champions will be crowned at National Productivity Summit 2018 24 - 25 August 2018, Chennai**

**Rush your entries by 7 April 2018**



**IMTMA - ACE MICROMATIC Productivity Championship Awards 2018**

*"Showcasing Competitiveness in Manufacturing"*



Indian Machine Tool Manufacturers' Association  
www.imtma.in

Awards Sponsor



For more details, contact :  
**Mr. Abhishek on 080- 66246829 / 6665**  
Mobile : +91 9886611007  
Email : abhishek@imtma.in



# EMC designed for higher production output

The Mazak EXTENSIBLE MANUFACTURING CELL is designed for continuous automatic operation 24 hours a day. As a result, more time is spent cutting to add value to worksheets for lower cost as well as reduced in-process time and inventory.

Single machine /  
single shift operation

EXTENSIBLE  
MANUFACTURING  
CELL

Continuous  
24 hour  
operation

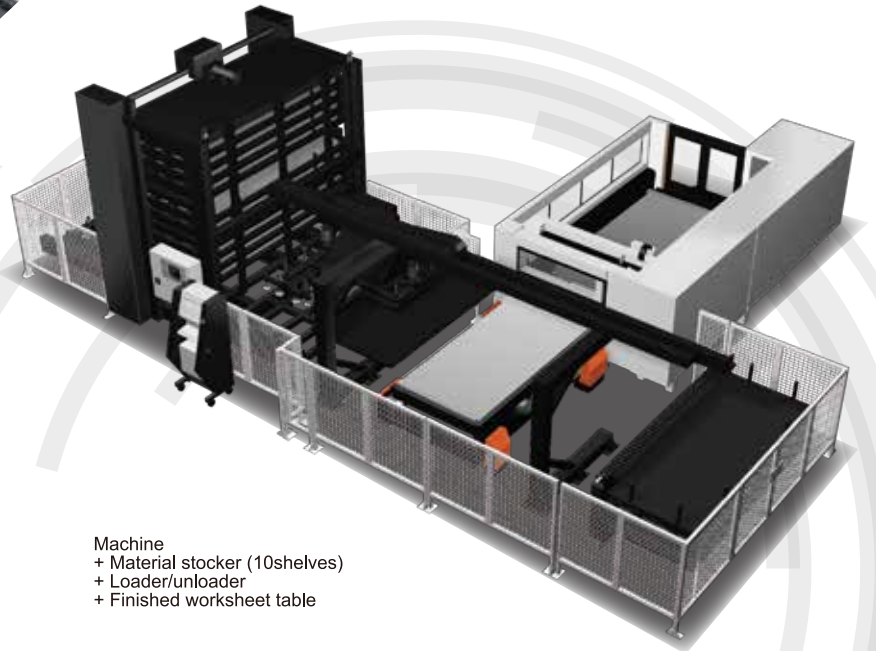
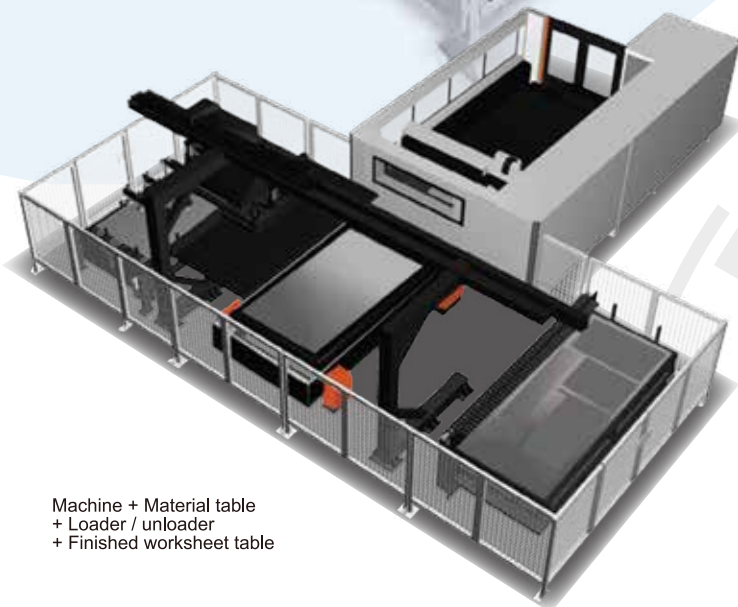

Newest version of the most widely used laser FMS in the world

## EXTENSIBLE MANUFACTURING CELL

# Mazak

Your Partner for Innovation

Yamazaki Mazak India Pvt Ltd

115, Pune Nagar Road, Sanaswadi, Pune. 412208. India Tel No - +(91)-2137-668800. Fax No. +(91)-2137-668829 www.mazakindia.in



PLEASE VISIT  
OUR BOOTH! >>>  
Hall 4 / Stall B102





# MACHINE UPGRADES WITH YOUR GROWING NEEDS

## HIGH POWER FIBER LASER 2D AND TUBE CUTTING SYSTEM

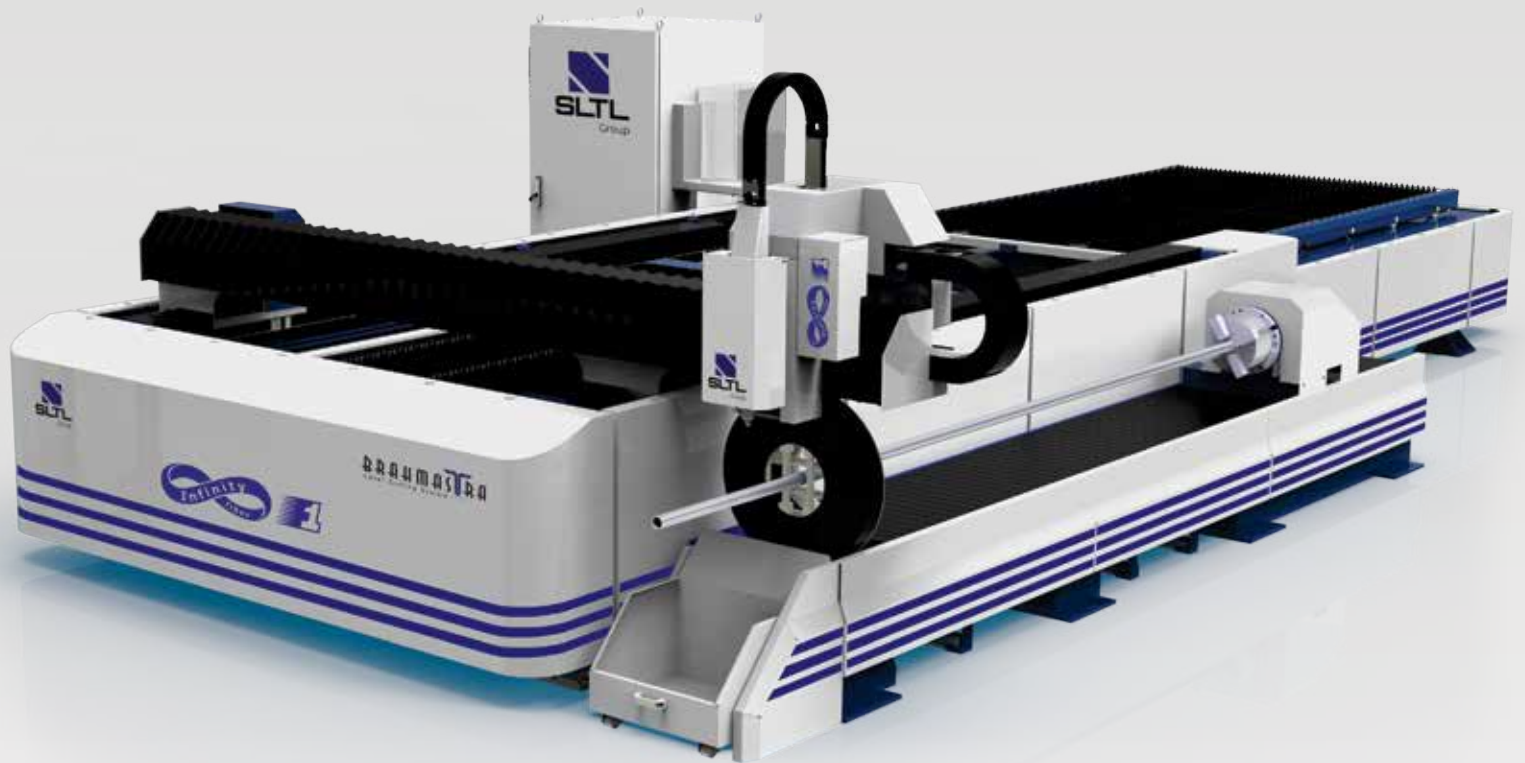

What we are showing today  
the world will show tomorrow

Hall No. 2A  
Booth No. B 106



Is Now



 [mkt@SLTL.com](mailto:mkt@SLTL.com)

 +91 9925036495

 [www.SLTL.com](http://www.SLTL.com)

SAHAJANAND LASER TECHNOLOGY LTD.